

2024

FY35

VIPER

LIFT TRUCKS



STANDARD FEATURES

- 8,000lb Base Capacity
- 3 Stage Mast
- Full Free Lift
- 89" Lowered Mast Height
- 189" Max Raised Fork Height
- Premium Air Pneumatic tires
- Backup Alarm
- Rear View Mirrors
- LED Front and Rear Lights
- Integrated LED Turn Signals
- Tilt Steering Column
- Twin USB Power Ports for Electric personal or Business Devices
- Digital Systems Monitor Display
- Rubber Floor mat
- Load Backrest
- 3 Way Hydraulics Plumbed to Carriage
- 12mo/2000hr Manufacturer Warranty



2024 FY35

SPECIFICATIONS

	LPG (OPTIONAL DUAL FUEL)
POWER TYPE	LPG
BASE CAPACITY	8000 LBS
CAPACITY 24" LC @189"	5400 LBS
SERVICE WEIGHT	11240 LBS
TIRE SIZE (FRONT)	28x9-15-14PR
TIRE SIZE (REAR)	6.50-10-10PR
WHEELBASE	67"
MAST TILT ANGLE (F/R)	6/12
LIFT HEIGHT (3 STAGE)	189"
LOWERED HEIGHT	89"
FREE LIFT	73"
LENGTH (LESS FORKS)	115"
WIDTH	48"
HEIGHT TO OVERHEAD GUARD	85"
TURNING RADIUS	97"
GROUND CLEARANCE	5.5"
MAX GRADABILITY	20%
TRANSMISSION	AUTO
TRANSMISSION SPEEDS	1 FWD / 1 RVS

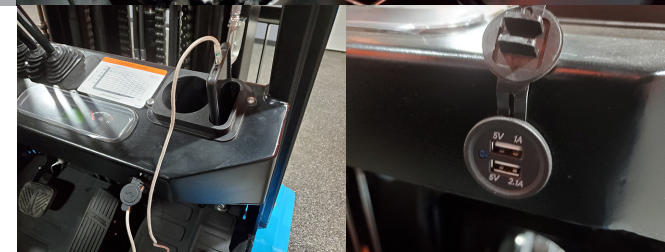
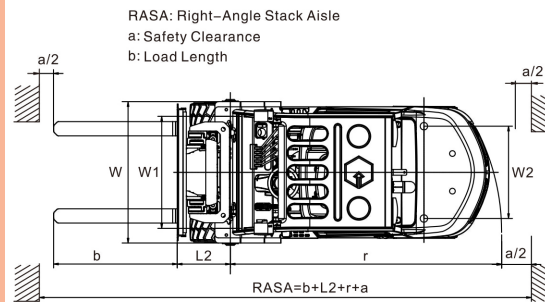
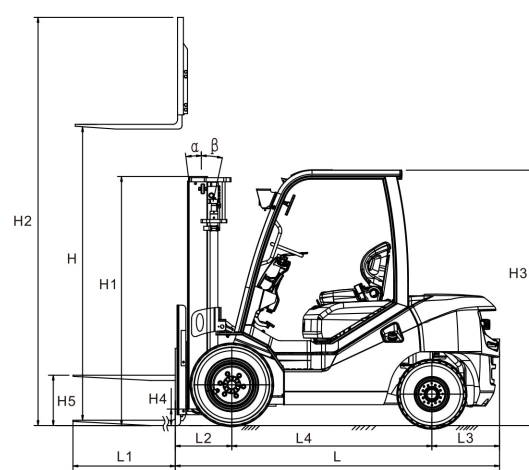

Engine model may vary

VIPER
LIFT TRUCKS



2024

FY35

PICK YOUR COLOR!

ORANGE



RED

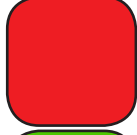

GREEN



ACID GREEN



SKY BLUE

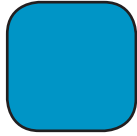

ROYAL BLUE



SILVER

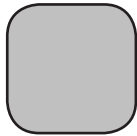

FROST GREY



WWW.VIPERLIFTTRUCKS.COM

FACTORY INSTALLED OPTIONS*

DUAL FUEL ENGINE

SOLID TIRES (4)

SOLID TIRES (6)

SIDE SHIFTER

SIDE SHIFT FORK POSITIONER

DUAL DRIVE W/WIDE CARRIAGE

FULL SUSPENSION SEAT

CAB W/HEAT, WIPERS, LED LIGHTS

AIR CONDITIONING

DUAL AIR FILTER (N/A W/ CAB)

VERTICAL EXHAUST

FIRE EXTINGUISHER

STROBE LIGHT

REAR WORK LIGHT

4TH VALVE, LEVER AND HOSEING

REAR HORN HANDLE/BUTTON

EATON STEERING



**EXTENDED WARRANTIES AVAILABLE
INQUIRE WITH YOUR REPRESENTATIVE
FOR FURTHER DETAILS**

VIPER
LIFT TRUCKS



VIPER

VIPER
LIFT TRUCKS

25

VIPER
LIFT TRUCKS
GENUINE PARTS

VIPER
LIFT TRUCKS

GENUINE PARTS

VIPER
LIFT TRUCKS

GENUINE PARTS

VIPER
LIFT TRUCKS

GENUINE PARTS

OIL FILTER