

2024 FY25C

VIPER
LIFT TRUCKS



STANDARD FEATURES

- 5,000lb Base Capacity
- 3 Stage Mast
- Full Free Lift
- 84" Lowered Mast Height
- 189" Max Raised Fork Height
- Premium Traction Cushion tires
- EPA Tier 4 Final Kubota 2.5L LPG Engine
- Engine Features 4cyl 61 HP @1600 RPM and 126 ft./lb TQ @1800 RPM
- Backup Alarm
- Rear View Mirrors
- LED Front and Rear Lights
- Integrated LED Turn Signals
- Tilt Steering Column
- Twin USB Power Ports for Electric personal or Business Devices
- Digital Systems Monitor Display
- Rubber Floor mat
- Load Backrest
- 3 Way Hydraulics Plumbed to Carriage
- 12mo/2000hr Manufacturer Warranty





2024

FY250

SPECIFICATIONS

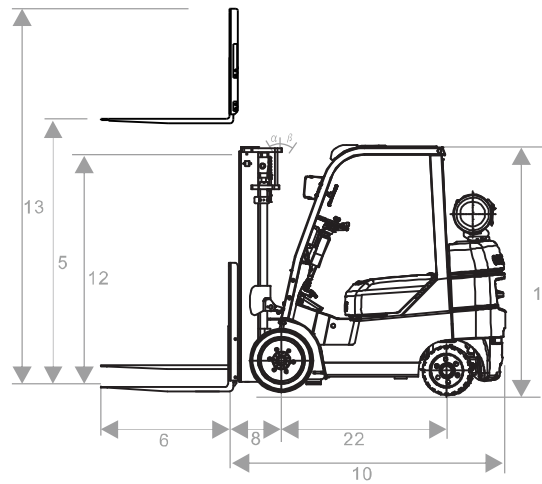
POWER TYPE	LPG	LPG (OPTIONAL DUAL FUEL)
BASE CAPACITY	5000 LBS	5000 LBS
CAPACITY 24" LC @189"	3900 LBS	3900 LBS
SERVICE WEIGHT	9041 LBS	9041 LBS
TIRE SIZE (FRONT)	21x7x15	21x7x15
TIRE SIZE (REAR)	16.25x6x11.25	16.25x6x11.25
WHEELBASE	55.1"	55.1"
MAST TILT ANGLE (F/R)	6/12	6/12
LIFT HEIGHT (3 STAGE)	189"	189"
LOWERED HEIGHT	84"	84"
FREE LIFT	73"	73"
LENGTH (LESS FORKS)	95"	95"
WIDTH	45"	45"
HEIGHT TO OVERHEAD GUARD	82"	82"
TURNING RADIUS	83"	83"
GROUND CLEARANCE	3.14"	3.14"
MAX GRADABILITY	20%	20%
TRANSMISSION	AUTO	AUTO
TRANSMISSION SPEEDS	1 FWD / 1 RVS	1 FWD / 1 RVS



 RASA: Right-Angle Stack Aisle
 a: Safety Clearance
 b: Length of Loading
 v: Turning radius (inside)

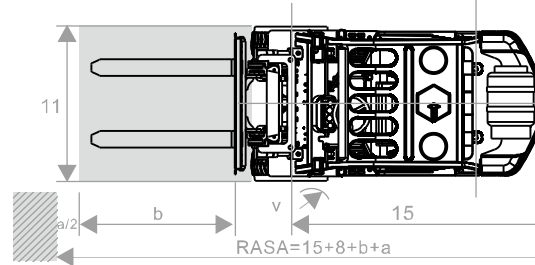

Engine model may vary



VIPER
LIFT TRUCKS

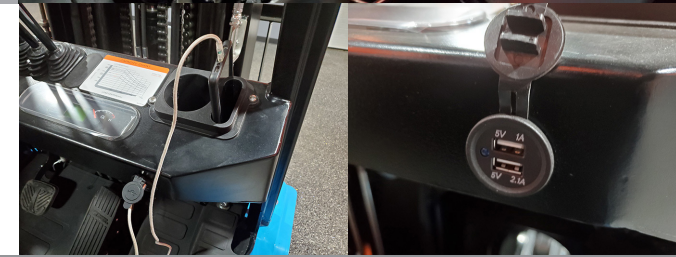

2024

FY25C

PICK YOUR COLOR!

ORANGE



RED

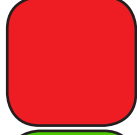

GREEN



ACID GREEN



SKY BLUE

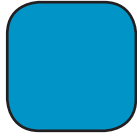

ROYAL BLUE



SILVER

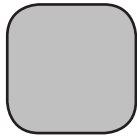

FROST GREY



FACTORY INSTALLED OPTIONS*

DUAL FUEL ENGINE

SIDE SHIFTER

SIDE SHIFT FORK POSITIONER

FULL SUSPENSION SEAT

CAB W/HEAT, WIPERS, LED LIGHTS

AIR CONDITIONING

DUAL AIR FILTER (N/A W/ CAB)

VERTICAL EXHAUST

FIRE EXTINGUISHER

STROBE LIGHT

REAR WORK LIGHT

4TH VALVE, LEVER AND HOSEING

REAR HORN HANDLE/BUTTON

EATON STEERING



**EXTENDED WARRANTIES AVAILABLE
INQUIRE WITH YOUR REPRESENTATIVE
FOR FURTHER DETAILS**

VIPER
LIFT TRUCKS

WWW.VIPERLIFTTRUCKS.COM



VIPER

VIPER
LIFT TRUCK

25

VIPER
LIFT TRUCKS
GENUINE PARTS

VIPER
LIFT TRUCKS
GENUINE PARTS

VIPER
LIFT TRUCKS
GENUINE PARTS

VIPER
LIFT TRUCKS
GENUINE PARTS

OIL FILTER