

# 2024

# FY25

## VIPER

LIFT TRUCKS



### STANDARD FEATURES

- 5,000lb Base Capacity
- 3 Stage Mast
- Full Free Lift
- 85" Lowered Mast Height
- 189" Max Raised Fork Height
- Premium Air Pneumatic tires
- Backup Alarm
- Rear View Mirrors
- LED Front and Rear Lights
- Integrated LED Turn Signals
- Tilt Steering Column
- Twin USB Power Ports for Electric personal or Business Devices
- Digital Systems Monitor Display
- Rubber Floor mat
- Load Backrest
- 3 Way Hydraulics Plumbed to Carriage
- 12mo/2000hr Manufacturer Warranty





# 2024 FY25

## SPECIFICATIONS

	LPG (OPTIONAL DUAL FUEL)
POWER TYPE	LPG
BASE CAPACITY	5000 LBS
CAPACITY 24" LC @189"	3900 LBS
SERVICE WEIGHT	9150 LBS
TIRE SIZE (FRONT)	7.00-12-12PR
TIRE SIZE (REAR)	6.00-9-10PR
WHEELBASE	63"
MAST TILT ANGLE (F/R)	6/12
LIFT HEIGHT (3 STAGE)	189"
LOWERED HEIGHT	85"
FREE LIFT	73"
LENGTH (LESS FORKS)	108"
WIDTH	45"
HEIGHT TO OVERHEAD GUARD	84"
TURNING RADIUS	90"
GROUND CLEARANCE	4.33"
MAX GRADABILITY	20%
TRANSMISSION	AUTO
TRANSMISSION SPEEDS	1 FWD / 1 RVS

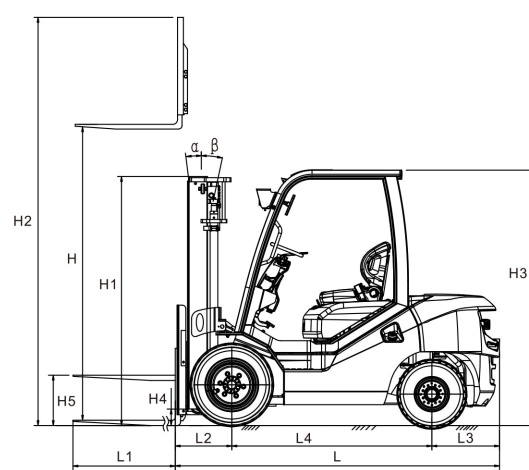

RASA: Right-Angle Stack Aisle

a: Safety Clearance

b: Load Length

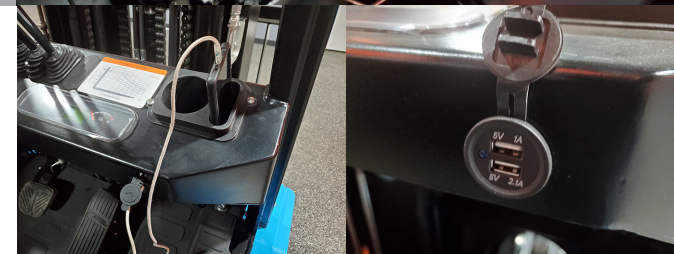
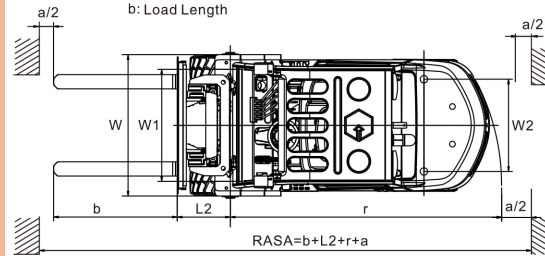

Engine model may vary

**VIPER**  
LIFT TRUCKS



# 2024

# FY25

## PICK YOUR COLOR!

**ORANGE**



**RED**

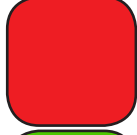

**GREEN**

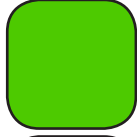

**ACID GREEN**



**SKY BLUE**

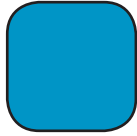

**ROYAL BLUE**



**SILVER**

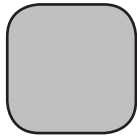

**FROST GREY**



## FACTORY INSTALLED OPTIONS\*

DUAL FUEL ENGINE

SOLID TIRES (4)

SOLID TIRES (6)

SIDE SHIFTER

SIDE SHIFT FORK POSITIONER

DUAL DRIVE W/WIDE CARRIAGE

FULL SUSPENSION SEAT

CAB W/HEAT, WIPERS, LED LIGHTS

AIR CONDITIONING

DUAL AIR FILTER (N/A W/ CAB)

VERTICAL EXHAUST

FIRE EXTINGUISHER

STROBE LIGHT

REAR WORK LIGHT

4TH VALVE, LEVER AND HOISING

REAR HORN HANDLE/BUTTON

EATON STEERING



**EXTENDED WARRANTIES AVAILABLE  
INQUIRE WITH YOUR REPRESENTATIVE  
FOR FURTHER DETAILS**

**VIPER**  
LIFT TRUCKS

WWW.VIPERLIFTTRUCKS.COM





VIPER

VIPER  
LIFT TRUCKS

25

VIPER

OIL FILTER

VIPER  
LIFT TRUCKS  
GENUINE PARTS

VIPER  
LIFT TRUCKS

GENUINE PARTS

VIPER  
LIFT TRUCKS

GENUINE PARTS

VIPER  
LIFT TRUCKS

GENUINE PARTS