

# 2024

# FD50S



## STANDARD FEATURES

- 11,000lb Base Capacity
- 3 Stage Mast
- Full Free Lift
- 91" Lowered Mast Height
- 189" Max Raised Fork Height
- Premium Air Pneumatic tires
- EPA Tier 4 Final Cummins engine QSF2.8L Turbo Diesel Engine
- Engine Features 3cyl 65 HP and 200 ft/lb TQ
- Backup Alarm
- Rear View Mirrors
- LED Front and Rear Lights
- Integrated LED Turn Signals
- Tilt Steering Column
- Digital Systems Monitor Display
- Rubber Floor mat
- Load Backrest
- 3 Way Hydraulics Plumbed to Carriage
- 48" Forks
- 12mo/2000hr Manufacturer Warranty
- 1 Year/2000hr Cummins Engine Warranty



# 2024 FD50S

## SPECIFICATIONS

POWER TYPE	<b>DIESEL</b>
BASE CAPACITY	<b>11000 LBS</b>
CAPACITY 24" LC @189"	<b>8100 LBS</b>
SERVICE WEIGHT	<b>16530 LBS</b>
TIRE SIZE (FRONT)	<b>300-15-18 PR</b>
TIRE SIZE (REAR)	<b>7.00-12-12 PR</b>
WHEELBASE	<b>83"</b>
MAST TILT ANGLE (F/R)	<b>6/12</b>
LIFT HEIGHT (3 STAGE)	<b>189"</b>
LOWERED HEIGHT	<b>91"</b>
FREE LIFT	<b>73"</b>
LENGTH (LESS FORKS)	<b>128"</b>
WIDTH	<b>57.5"</b>
HEIGHT TO OVERHEAD GUARD	<b>92.12"</b>
TURNING RADIUS	<b>114.5"</b>
GROUND CLEARANCE	<b>6"</b>
MAX GRADABILITY	<b>20%</b>
TRANSMISSION	<b>AUTO</b>
TRANSMISSION SPEEDS	<b>2 FWD / 1 RVS</b>

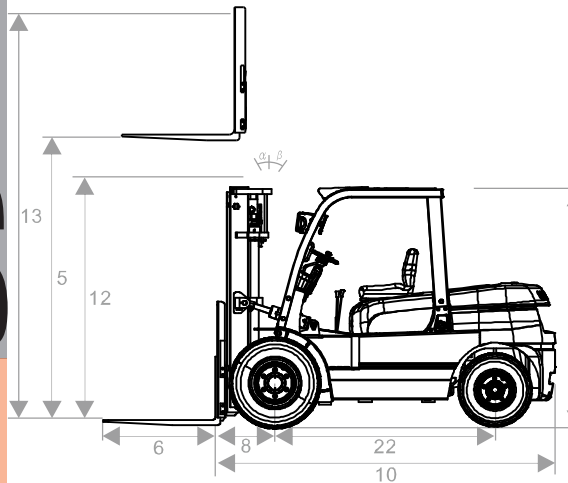

 RASA: Right-Angle Stack Aisle  
 a: Safety Clearance  
 b: Length of Loading  
 v: Turning radius (inside)

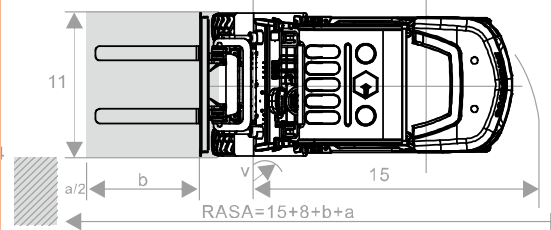

[CLICK FOR ENGINE BROCHURE](#)

**VIPER**  
LIFT TRUCKS

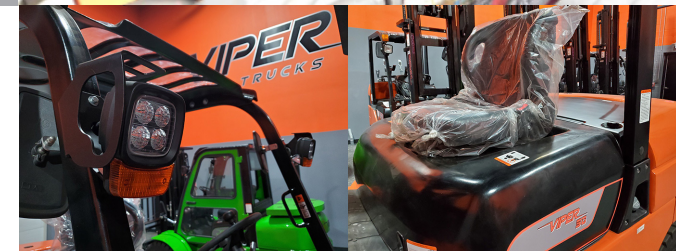

# 2024

# FD50S

## PICK YOUR COLOR!

**ORANGE**



**RED**

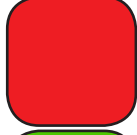

**GREEN**

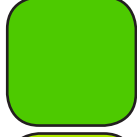

**ACID GREEN**



**SKY BLUE**



**ROYAL BLUE**



**SILVER**



**FROST GREY**

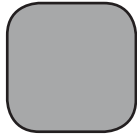

WWW.VIPERLIFTTRUCKS.COM

## FACTORY INSTALLED OPTIONS\*

SIDE SHIFTER

SIDE SHIFT FORK POSITIONER

SIDE SHIFT FORK POSITIONER

w/WIDE CARRIAGE

DUAL DRIVE WIDE CARRIAGE

FULL SUSPENSION SEAT

CAB W/HEAT, WIPERS, LED LIGHTS

AIR CONDITIONING

FIRE EXTINGUISHER

STROBE LIGHT

REAR WORK LIGHT

4TH VALVE, LEVER AND HOSING

REAR HORN HANDLE/BUTTON

EATON STEERING

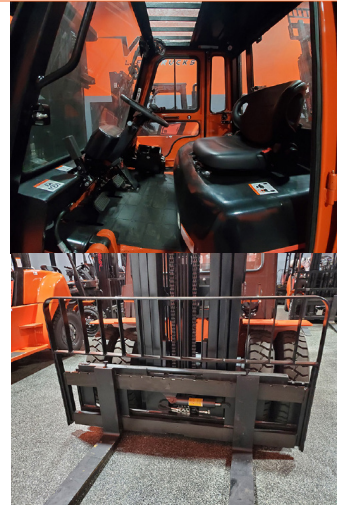

**EXTENDED WARRANTIES AVAILABLE  
INQUIRE WITH YOUR REPRESENTATIVE  
FOR FURTHER DETAILS**

**VIPER**  
LIFT TRUCKS



VIPER

VIPER  
LIFT TRUCKS

25

VIPER

VIPER  
LIFT TRUCKS  
GENUINE PARTS

VIPER  
LIFT TRUCKS

GENUINE PARTS

VIPER  
LIFT TRUCKS

GENUINE PARTS

VIPER  
LIFT TRUCKS

GENUINE PARTS

OIL FILTER