

# 2024

# FD25

## STANDARD FEATURES

- 5,000lb Base Capacity
- 3 Stage Mast
- Full Free Lift
- 85" Lowered Mast Height
- 189" Max Raised Fork Height
- Premium Air Pneumatic tires
- EPA Tier 4 Diesel Engine
- Backup Alarm
- Rear View Mirrors
- LED Front and Rear Lights
- Integrated LED Turn Signals
- Tilt Steering Column
- Twin USB Power Ports for Electric personal or Business Devices
- Digital Systems Monitor Display
- Rubber Floor mat
- Load Backrest
- 3 Way Hydraulics Plumbed to Carriage
- 12mo/2000hr Manufacturer Warranty

# VIPER

LIFT TRUCKS





# 2024 FD25

## SPECIFICATIONS

POWER TYPE	LPG	<b>DIESEL</b>
BASE CAPACITY	5000 LBS	<b>5000 LBS</b>
CAPACITY 24" LC @189"	3900 LBS	<b>3900 LBS</b>
SERVICE WEIGHT	9150 LBS	<b>9150 LBS</b>
TIRE SIZE (FRONT)	7.00-12-12PR	<b>7.00-12-12PR</b>
TIRE SIZE (REAR)	6.00-9-10PR	<b>6.00-9-10PR</b>
WHEELBASE	63"	<b>63"</b>
MAST TILT ANGLE (F/R)	6/12	<b>6/12</b>
LIFT HEIGHT (3 STAGE)	189"	<b>189"</b>
LOWERED HEIGHT	85"	<b>85"</b>
FREE LIFT	73"	<b>73"</b>
LENGTH (LESS FORKS)	108"	<b>108"</b>
WIDTH	45"	<b>45"</b>
HEIGHT TO OVERHEAD GUARD	84"	<b>84"</b>
TURNING RADIUS	90"	<b>90"</b>
GROUND CLEARANCE	4.33"	<b>4.33"</b>
MAX GRADABILITY	20%	<b>20%</b>
TRANSMISSION	AUTO	<b>AUTO</b>
TRANSMISSION SPEEDS	1 FWD / 1 RVS	<b>1 FWD / 1 RVS</b>

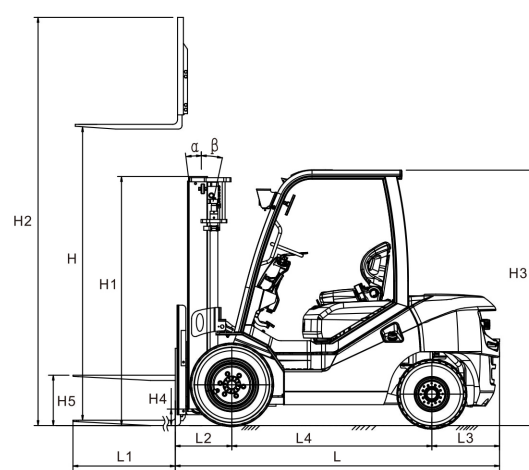

RASA: Right-Angle Stack Aisle  
a: Safety Clearance  
b: Load Length

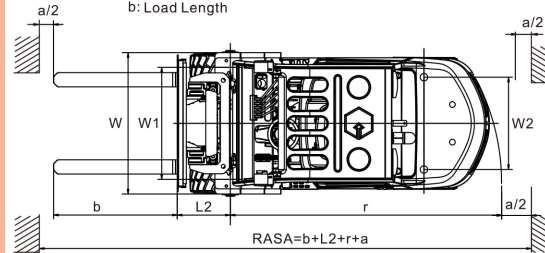

Engine model may vary

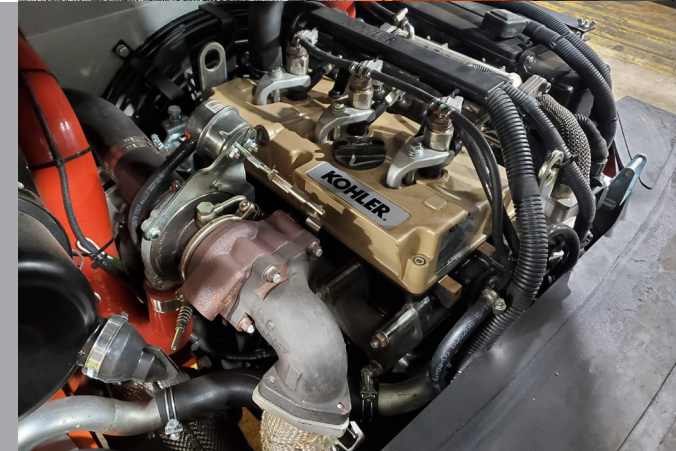

**VIPER**  
LIFT TRUCKS

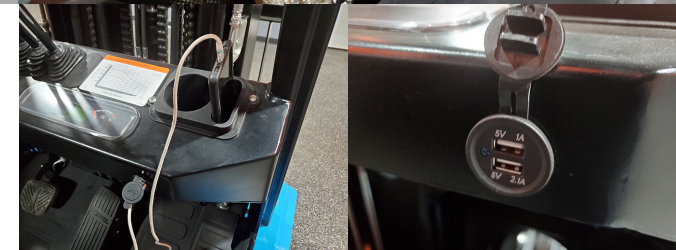

# 2024

# FD25

## PICK YOUR COLOR!

**ORANGE**



**RED**



**GREEN**

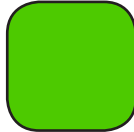

**ACID GREEN**



**SKY BLUE**

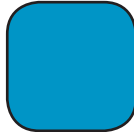

**ROYAL BLUE**



**SILVER**

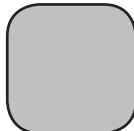

**FROST GREY**



## FACTORY INSTALLED OPTIONS\*

SOLID TIRES (4)

SOLID TIRES (6)

SIDE SHIFTER

SIDE SHIFT FORK POSITIONER

DUAL DRIVE W/WIDE CARRIAGE

FULL SUSPENSION SEAT

CAB W/HEAT, WIPERS, LED LIGHTS

AIR CONDITIONING

DUAL AIR FILTER (N/A W/ CAB)

VERTICAL EXHAUST

FIRE EXTINGUISHER

STROBE LIGHT

REAR WORK LIGHT

4TH VALVE, LEVER AND HOSING

REAR HORN HANDLE/BUTTON

EATON STEERING



**EXTENDED WARRANTIES AVAILABLE  
INQUIRE WITH YOUR REPRESENTATIVE  
FOR FURTHER DETAILS**

**VIPER**  
LIFT TRUCKS

WWW.VIPERLIFTTRUCKS.COM





VIPER

VIPER  
LIFT TRUCKS

25

VIPER

OIL FILTER

VIPER  
LIFT TRUCKS  
GENUINE PARTS

VIPER  
LIFT TRUCKS

GENUINE PARTS

VIPER  
LIFT TRUCKS

GENUINE PARTS

VIPER  
LIFT TRUCKS

GENUINE PARTS